

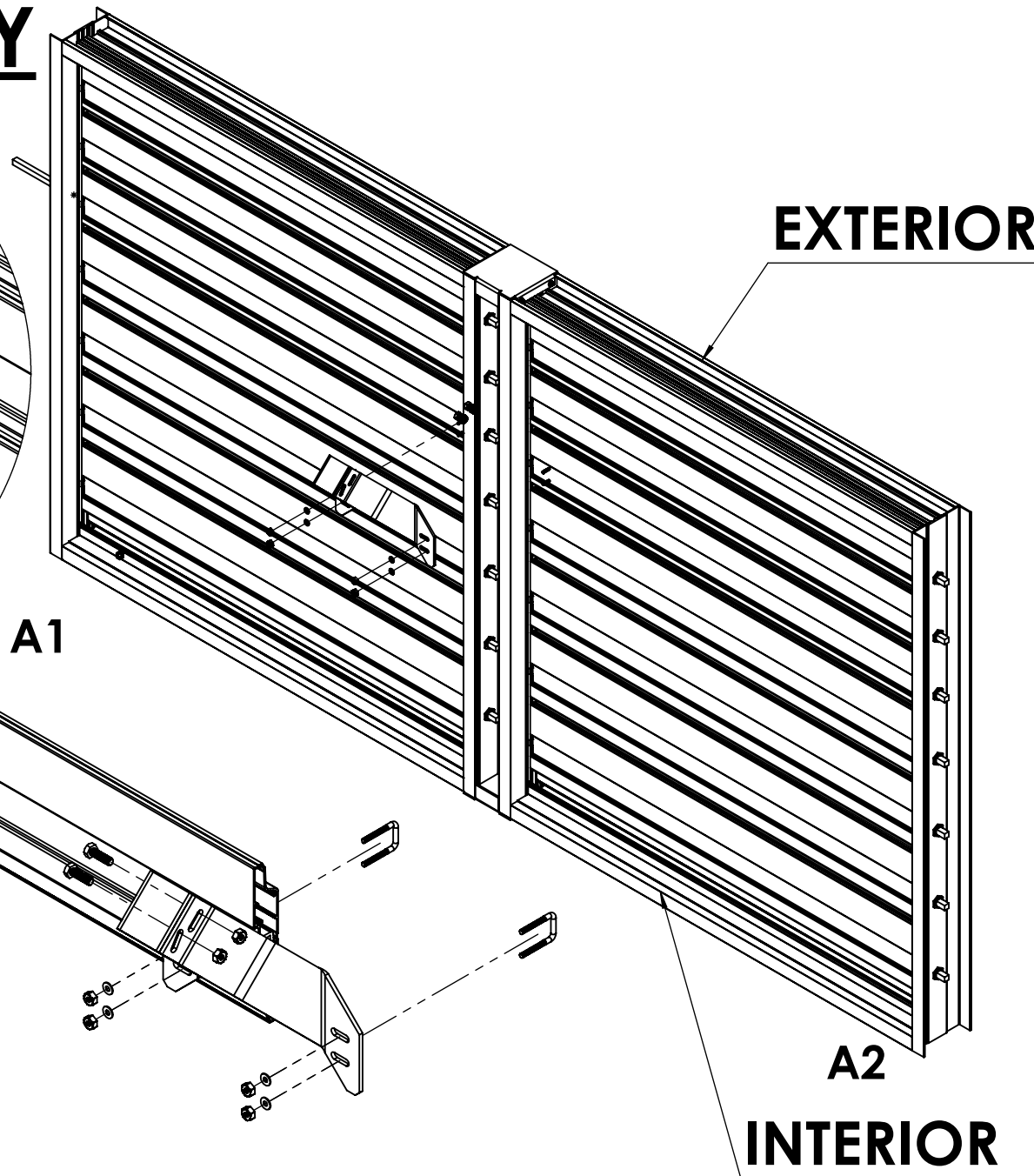

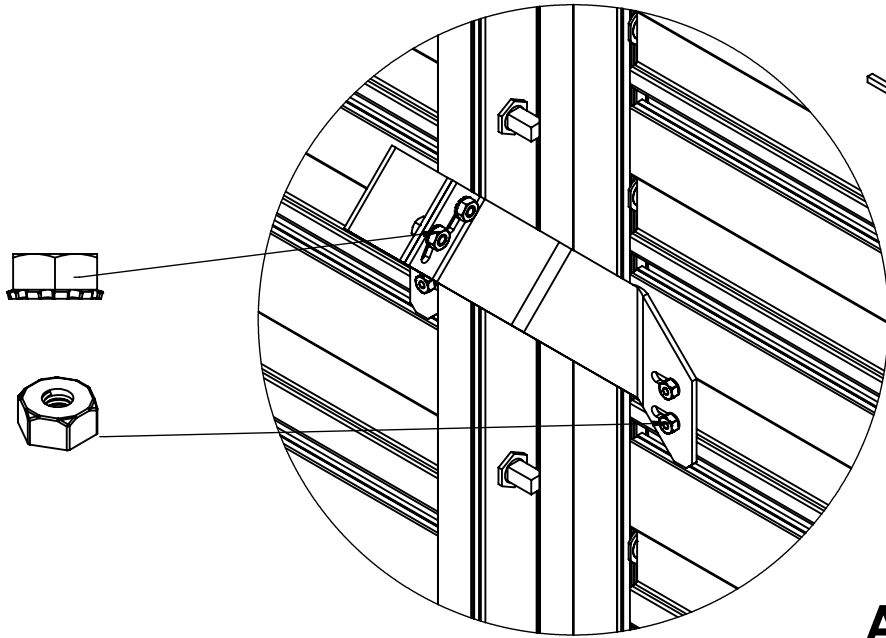

JUMPER ASSEMBLY



	(4)	MOUNTING HARDWARE PRE- INSTALLED / QUINCAILLERIE D'ASSEMBLAGE PRÉ-INSTALLÉ
	(2)	
	(4)	Y4-00111- SCREW-ZINC
	(2)	
	(2)	Y3-00175-LOCK NUT-ZINC

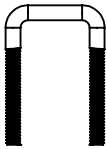

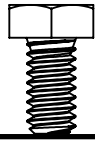
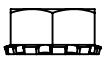
3000 SERIES CONTROL DAMPER JUMPER INSTALLATION

DETAIL A
SCALE 1 : 8

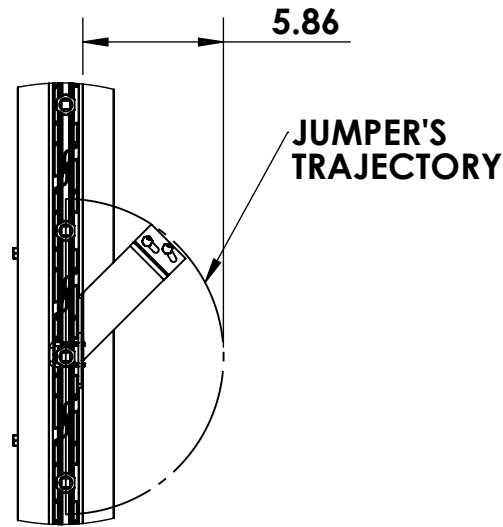

1. U-BOLT
2. WASHER
3. HEX NUT
4. HEX CAP SCREW
5. JUMPER(LEFT SIDE)
6. JUMPER(RIGHT SIDE)

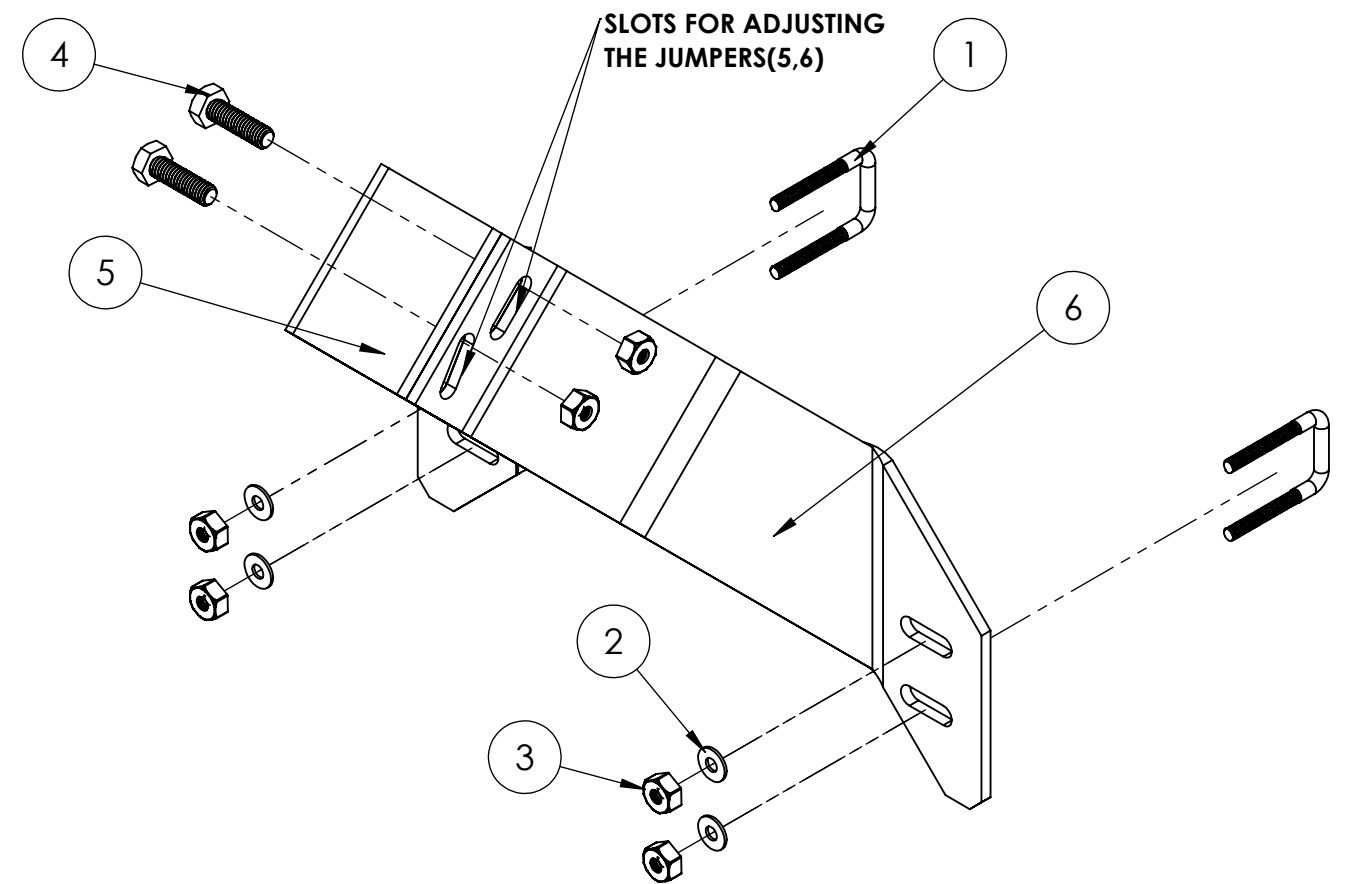
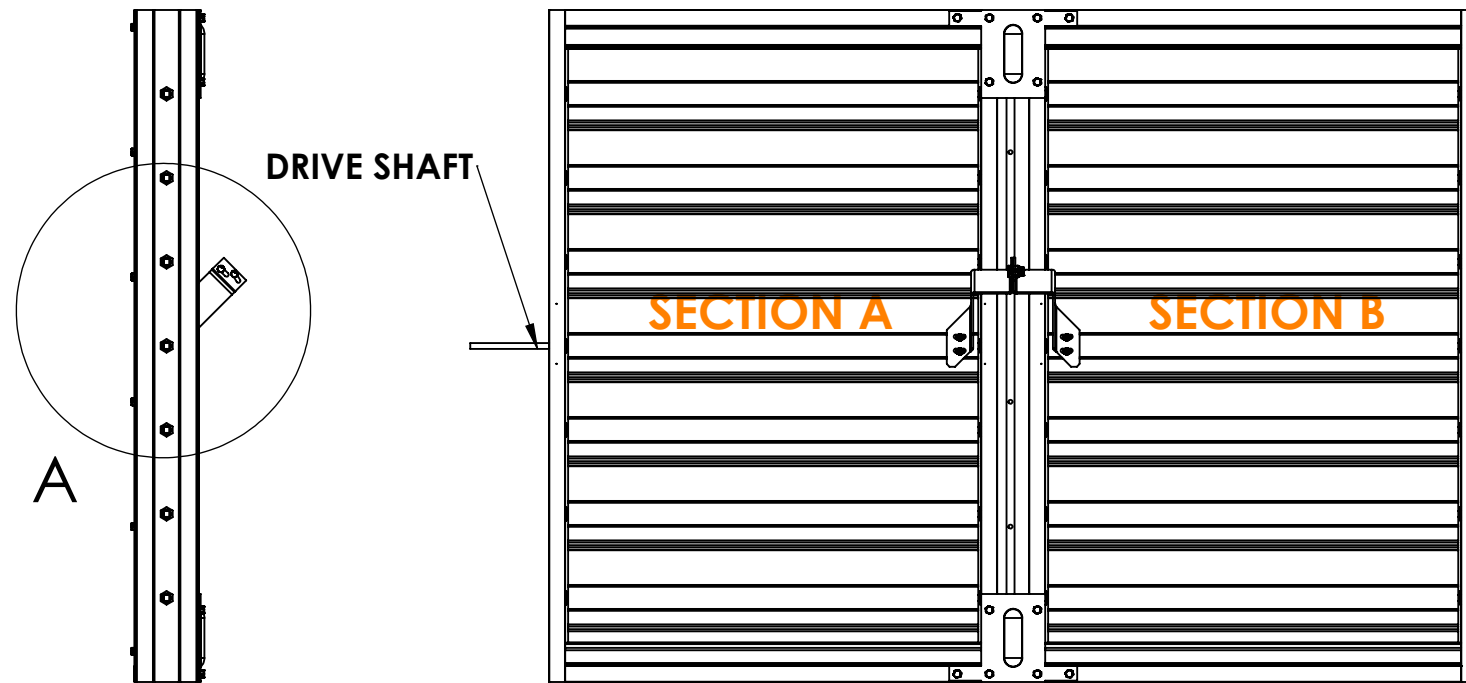

STEP 1: REMOVE EXISTING HEX NUTS AND WASHERS FROM U-BOLTS ON DRIVE BLADES. DO NOT REMOVE U-BOLT.

STEP 2: ATTACH JUMPERS TO U-BOLTS (ON DRIVE BLADES) AND FASTEN WITH HEX NUTS AND WASHERS THAT WERE REMOVED FROM STEP 1.

STEP 3: FASTEN JUMPERS (5,6) TOGETHER WITH HEX CAP SCREWS AND HEX NUTS AS SHOWN.

NOTE : THE SLOTS ALLOW SLIGHT ADJUSTMENT BETWEEN THE JUMPERS(5,6) TO ENSURE THAT BLADES CLOSE TIGHTLY IN 'SECTION B' WHICH IS FURTHER FROM THE ACTUATOR.

STEP 4: CYCLE THE DAMPER MANUALLY TO ENSURE SMOOTH OPERATION.

	222 Church St S, Allston, ON L9E 2B7 TEL: 905-857-4700 FAX: 905-857-4730 TOLL FREE: 1-800-468-7214 www.ventexinc.com	UNLESS OTHERWISE SPECIFIED ALL DIMENSIONS ARE IN INCHES. ALL DIMENSIONS IN () ARE METRIC.		DO NOT SCALE DRAWING	REMOVE ALL BURRS & SHARP CORNERS	UNITS: INCHES (mm)
		DESIGNED BY: JAYNEEL	DATE: 2020-06-01	SCALE: 1:12	REVISION 0	
3965 56.000 X 40.000 - P21L	MATERIAL: FINISH: N/A	DRAWN BY: JAYNEEL	DATE: 2020-06-01	DRAFTER: JAYNEEL	SW FILE NAME: 1991	SIZE A



3000 SERIES CONTROL DAMPER JUMPER INSTALLATION

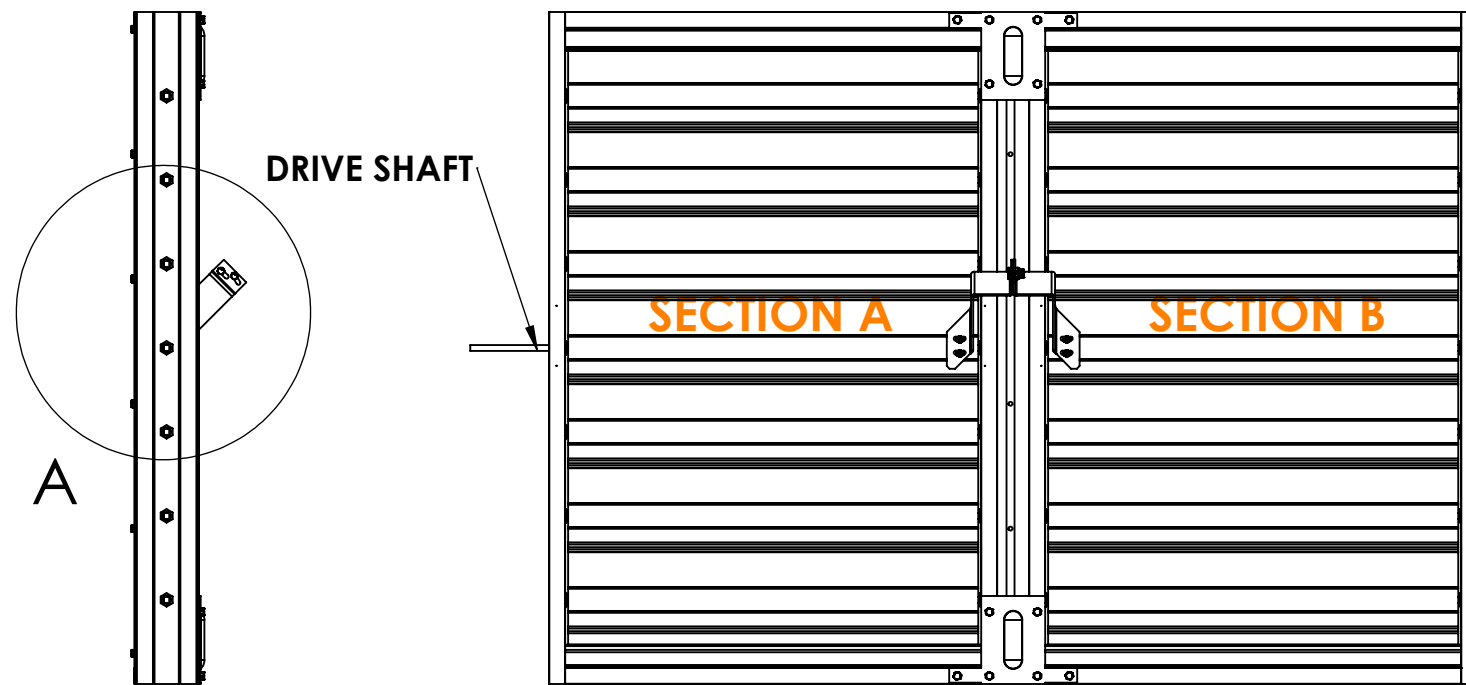

DETAIL A
SCALE 1 : 8

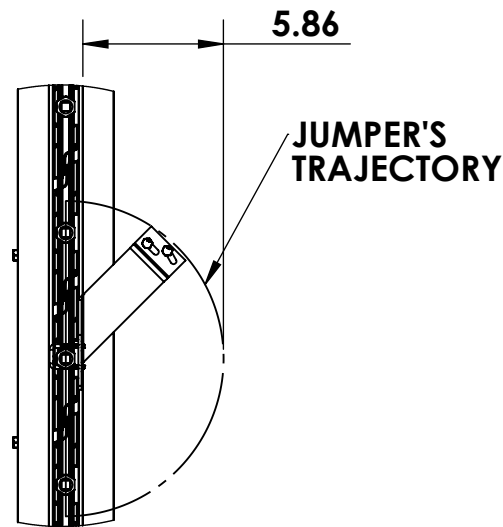

1. U-BOLT
2. WASHER
3. HEX NUT
4. HEX CAP SCREW
5. JUMPER(LEFT SIDE)
6. JUMPER(RIGHT SIDE)

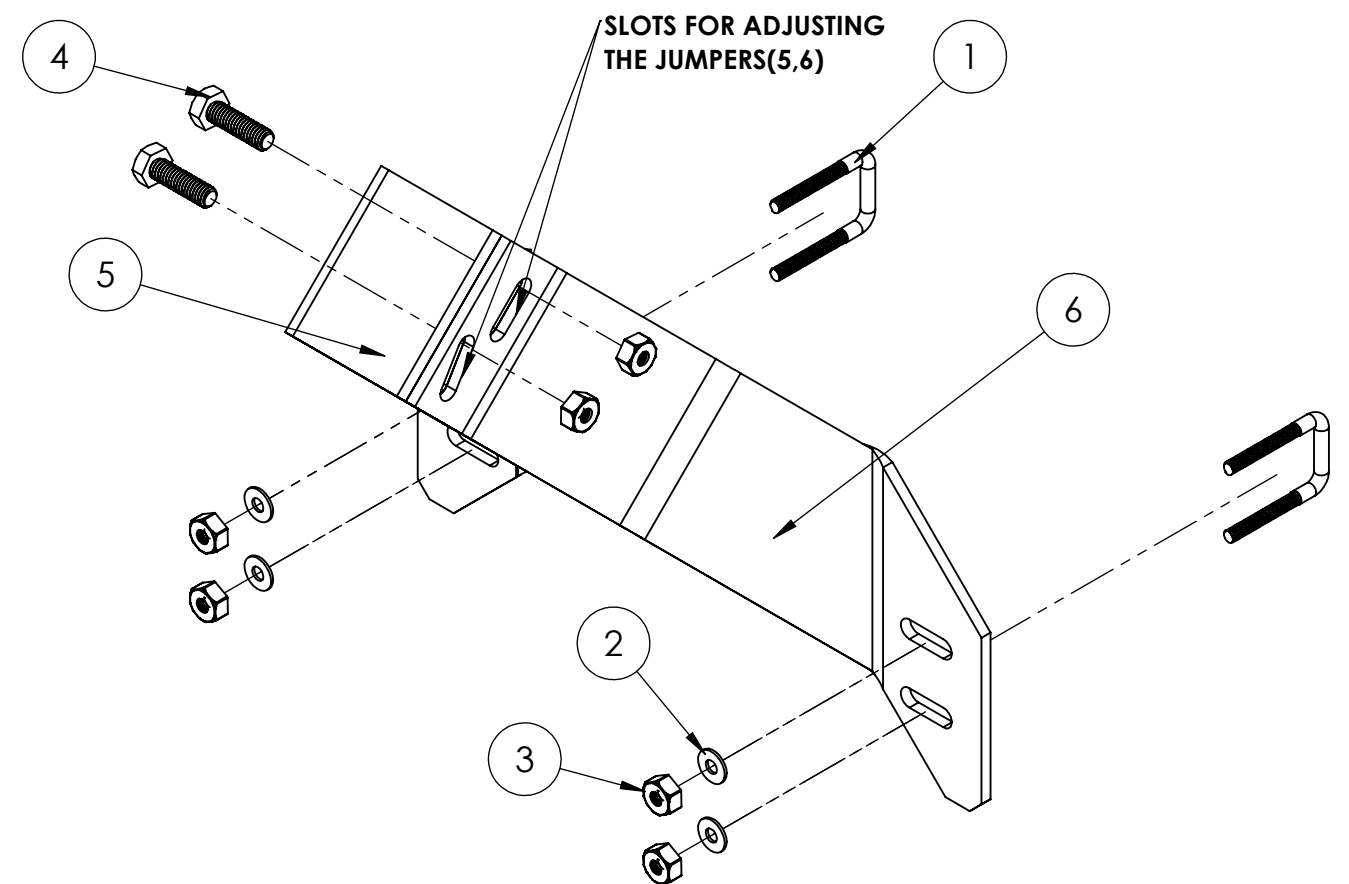

STEP 1: REMOVE EXISTING HEX NUTS AND WASHERS FROM U-BOLTS ON DRIVE BLADES. DO NOT REMOVE U-BOLT.

STEP 2: ATTACH JUMPERS TO U-BOLTS (ON DRIVE BLADES) AND FASTEN WITH HEX NUTS AND WASHERS THAT WERE REMOVED FROM STEP 1.

STEP 3: FASTEN JUMPERS (5,6) TOGETHER WITH HEX CAP SCREWS AND HEX NUTS AS SHOWN.

NOTE : THE SLOTS ALLOW SLIGHT ADJUSTMENT BETWEEN THE JUMPERS(5,6) TO ENSURE THAT BLADES CLOSE TIGHTLY IN 'SECTION B' WHICH IS FURTHER FROM THE ACTUATOR.

STEP 4: CYCLE THE DAMPER MANUALLY TO ENSURE SMOOTH OPERATION.

	222 Church St S, Alliston, ON L9R 2B7 TEL: 905-857-4700 FAX: 905-857-4730 TOLL FREE: 1-800-468-7214 www.ventexinc.com	UNLESS OTHERWISE SPECIFIED ALL DIMENSIONS ARE IN INCHES. ALL DIMENSIONS IN () ARE METRIC.		DO NOT SCALE DRAWING	REMOVE ALL BURRS & SHARP CORNERS	UNITS: INCHES (mm)
		DESIGNED BY: JAYNEEL	DATE: 2020-06-01	SCALE: 1:12	REVISION 0	
3965 56.000 X 40.000 - P21L	MATERIAL: FINISH: N/A	DRAWN BY: JAYNEEL	DATE: 2020-06-01	DRAFTER: JAYNEEL	SW FILE NAME: 1991	SIZE A